

CSE 250 Recitation

March 12 - 13: Graph Representations, PA2



Graph Representation

Exercise:

Write out an edge list implementation of this graph. Do the same for an adjacency list and adjacency matrix.

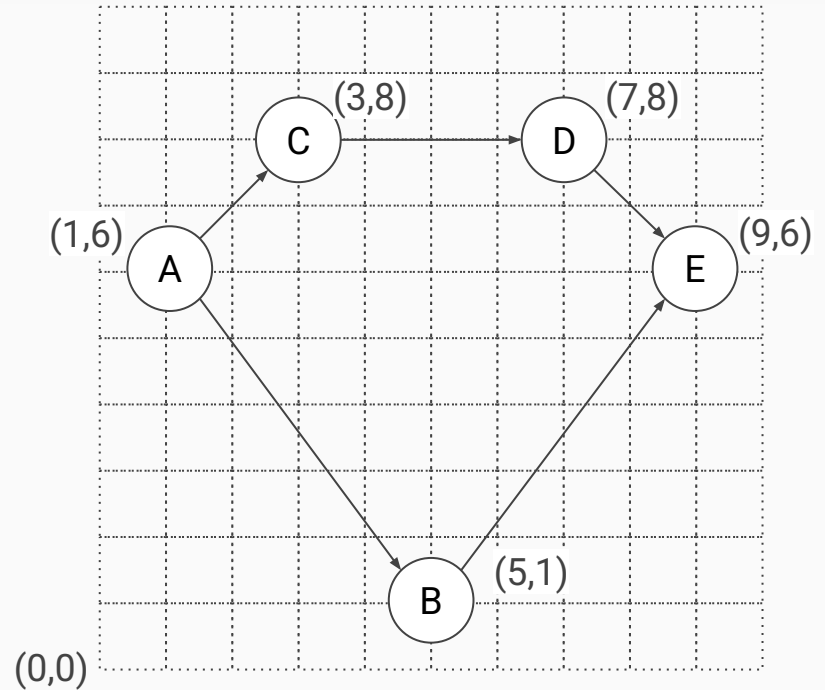

Graph Representation

Exercise:

Edge List:

[A, B, C, D, E]

[(A,C), (C,D), (D,E), (A,B), (B,E)]

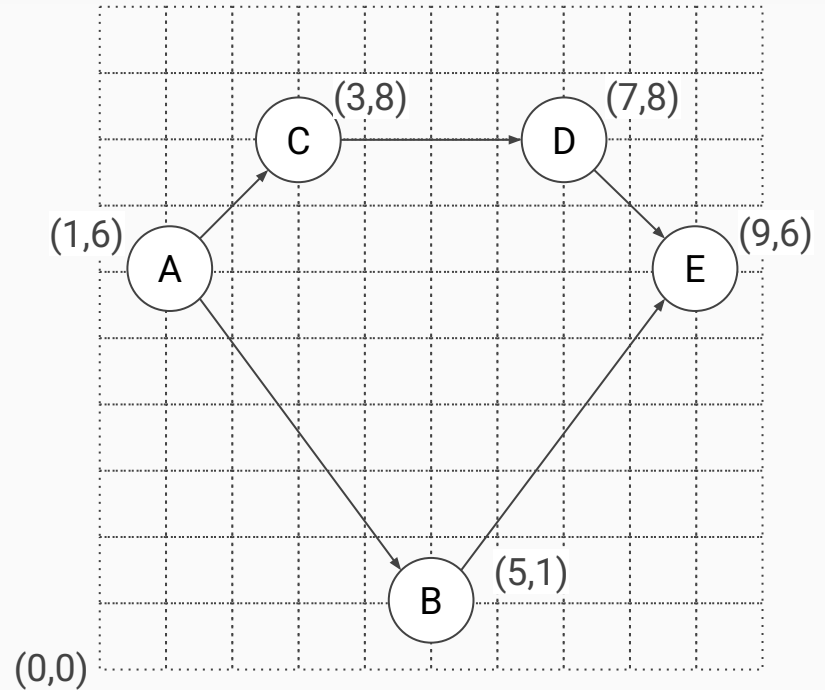

Graph Representation

Exercise:

Adjacency List

A: [(A,C),(A,B)]

B: [(B,E)]

C: [(C,D)]

D: [(D,E)]

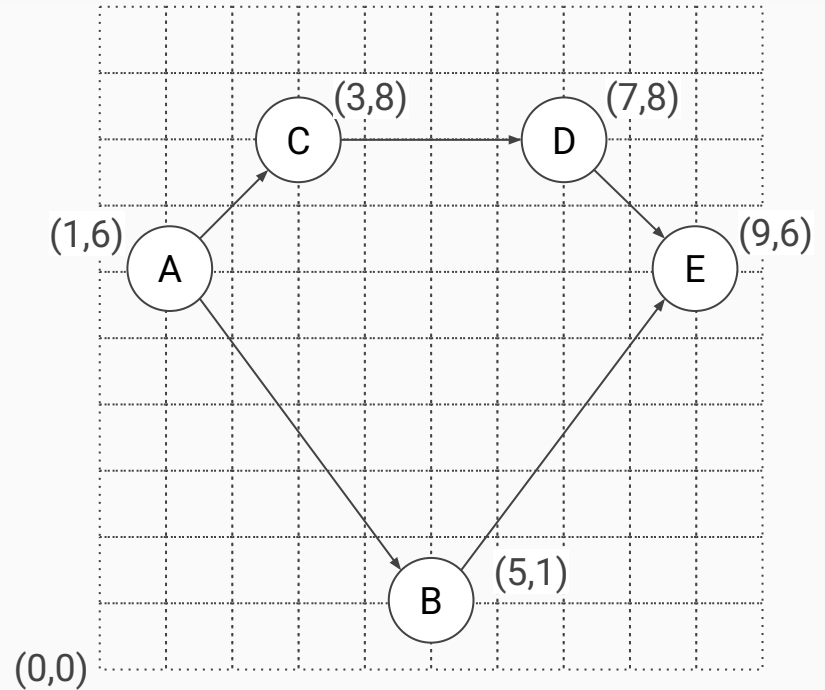

Graph Representation

Exercise:

Adjacency
Matrix

	A	B	C	D	E
A		(A,B)	(A,C)		
B					(B,E)
C				(C,D)	
D					(D,E)
E					

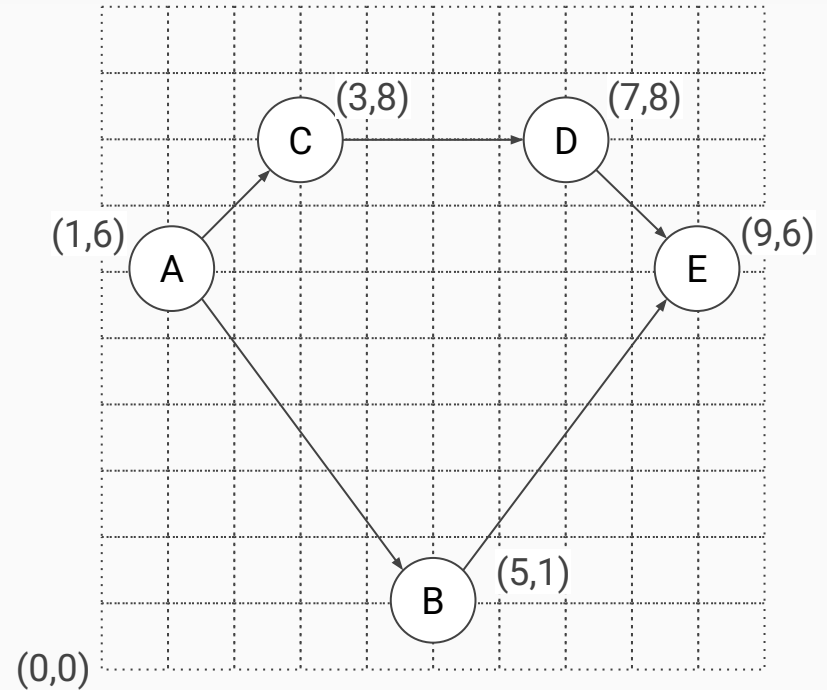

Traversal Discussion

Consider finding a path from A to E:

1. How many unique paths are there?
2. Which has the fewest edges?
 - a. Which algo finds this path?
3. Which has the shortest distance?
 - a. Which algo finds this path?
4. Which path would DFS find?

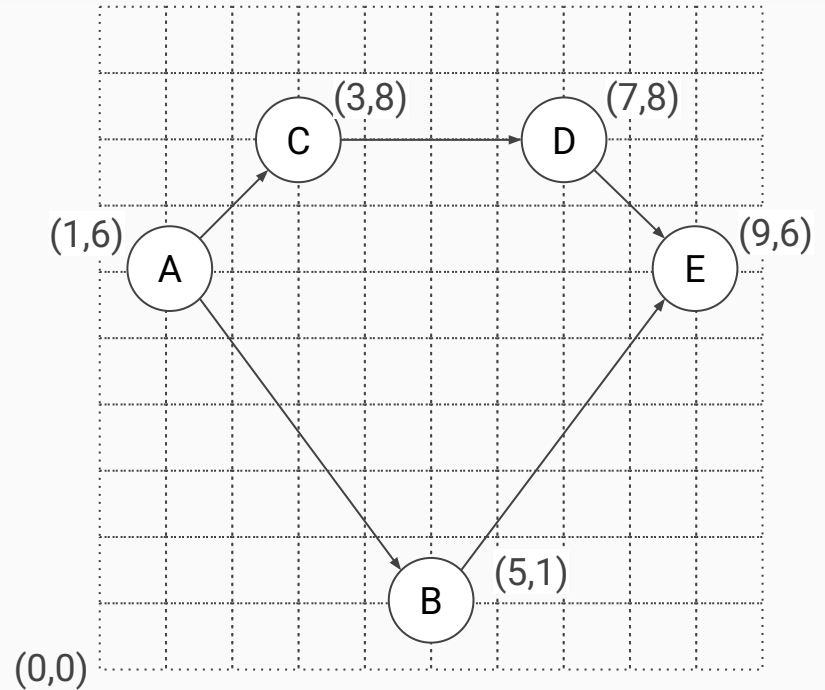

Traversal Discussion

Consider finding a path from A to E:

1. How many unique paths are there?
2. Which has the fewest edges?
 - a. Which algo finds this path?
3. Which has the shortest distance?
 - a. Which algo finds this path?
4. Which path would DFS find?

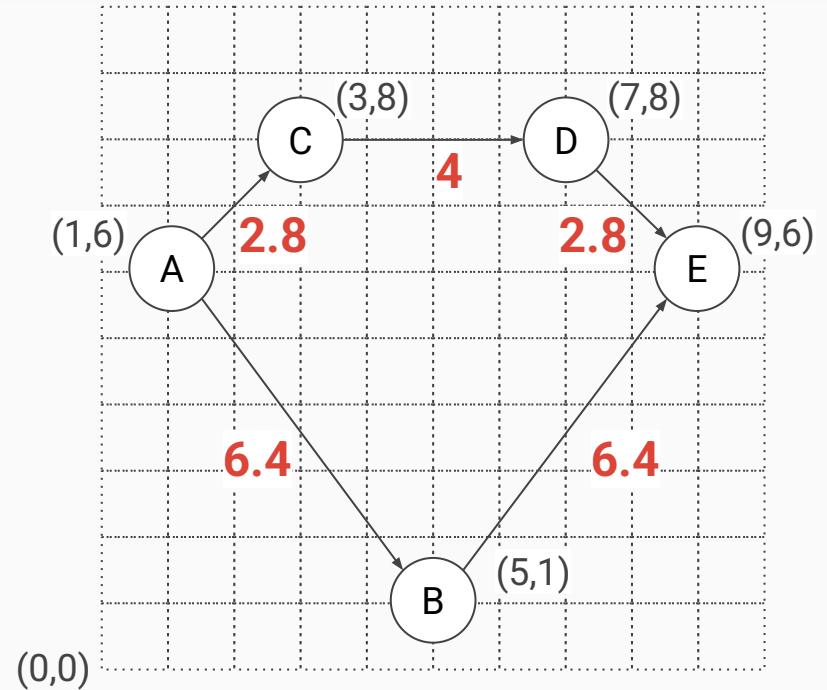

Traversal Discussion

Consider finding a path from A to E:

1. How many unique paths are there? **2**
2. Which has the fewest edges? **ABE**
 - a. Which algo finds this path? **BFS**
3. Which has the shortest distance? **ACDE**
 - a. Which algo finds this path? **Dijkstra's**
4. Which path would DFS find? **Either**

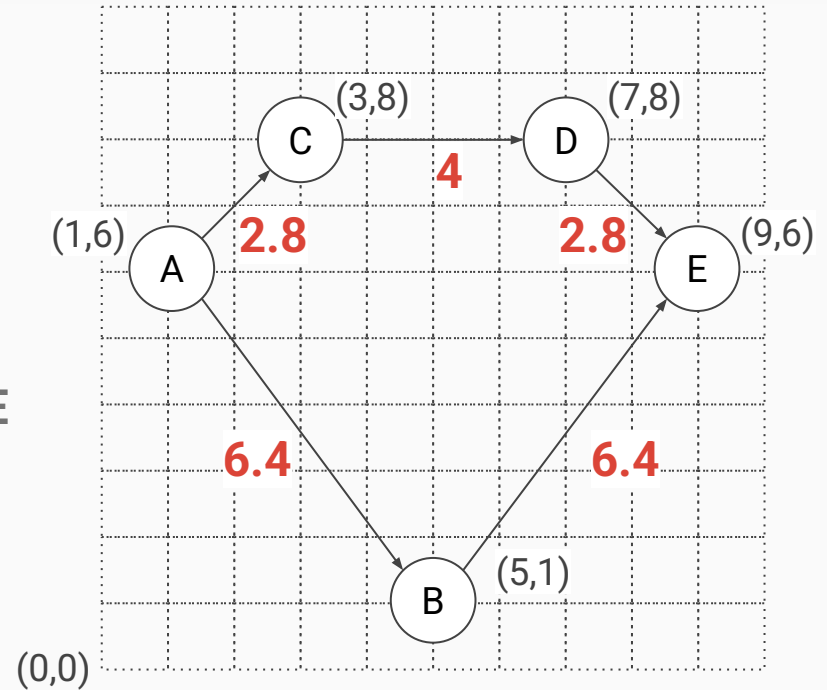

PA2: Testing Exercise

1. Draw out a graph containing *at least* 8 labeled vertices (with distances).
2. Label one of the vertices the starting vertex, and one the ending vertex.
3. Trade papers with a neighbor, and answer the following about their graph:
 - a. What is the path from start to finish with the fewest edges? Is it a unique path?
 - b. What is the path from start to finish of the shortest distance? Is it a unique path?
 - c. Are your answer to a and b the same? Why would it be problematic if they are?
 - d. Are the paths in a and b the **only** paths? Why would it be problematic if they are?
 - e. Name features that might show up in a map of Buffalo that are not present in this graph.
 - f. How would you change the graph to include some of these features?

Traversal Discussion Revisited

Based on the previous exercise:

1. What characteristics of this graph make it a good test?
2. What characteristics does it lack?
3. What could you add/change/include in a different test to improve your tests?

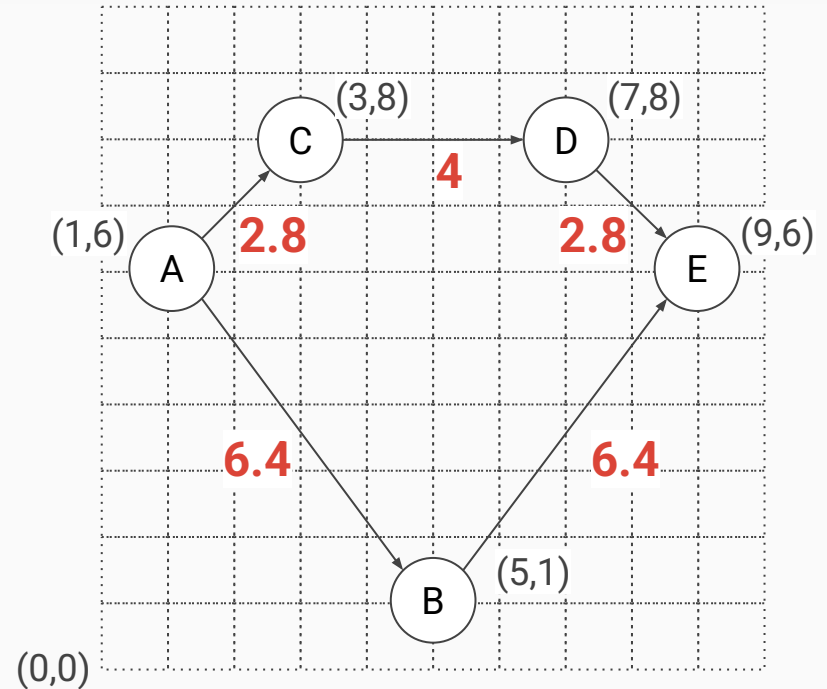

PA2: Testing Discussion

Did you need to know how to implement BFS/Dijkstra's to determine which paths should be found in your neighbors graph? **No!**

It's ok to have some very simple tests...but you should have complex ones too:

- If there's only one path...even a buggy implementation will probably find it
- If both BFS and Dijkstra's return the same path it may hide some bugs
- Buffalo streets have: cycles, two way streets, one way streets, dead ends
 - Could these features expose bugs in your search? Your tests should have these features!

Bonus Content: Tic Tac Toe Example

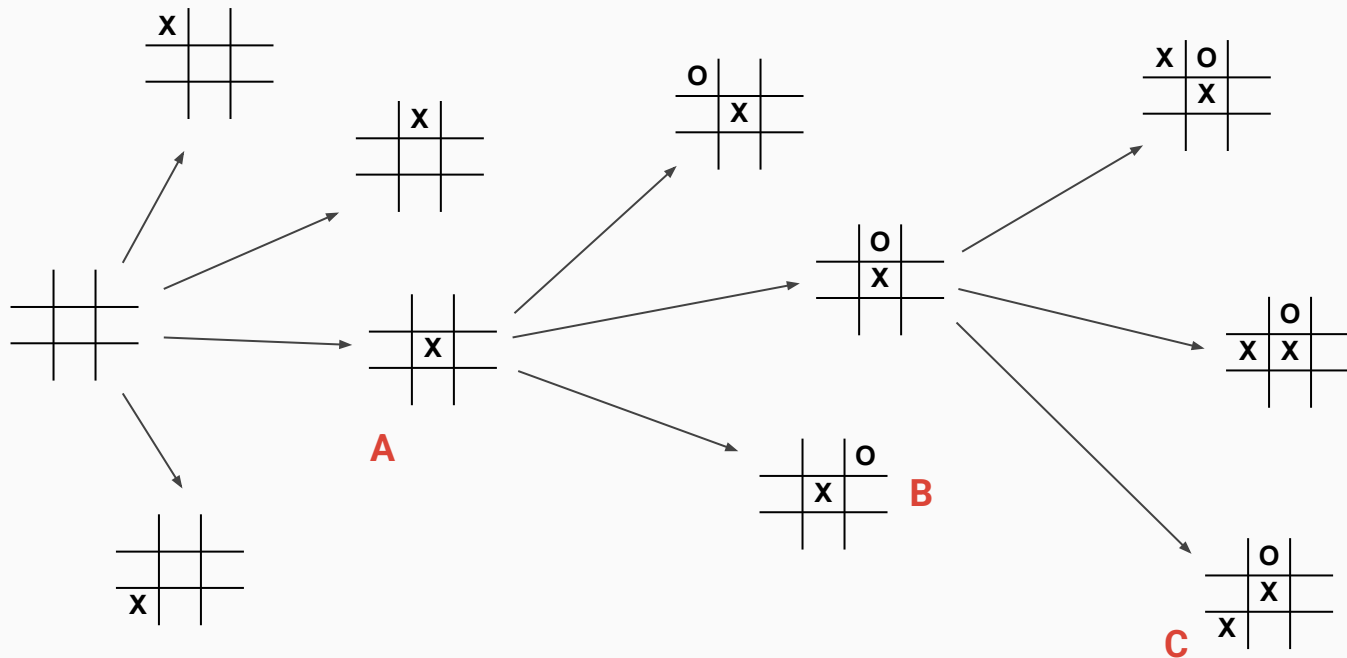

Note: This does not show all edges / vertices...

**What is the out degree of the vertex for the empty board?
What about the in degree?**

What is the out degree of the vertex labeled A? B?

How many edges are in the full graph?

Is the in degree of every non-starting node 1?

Bonus Content: Tic Tac Toe Example

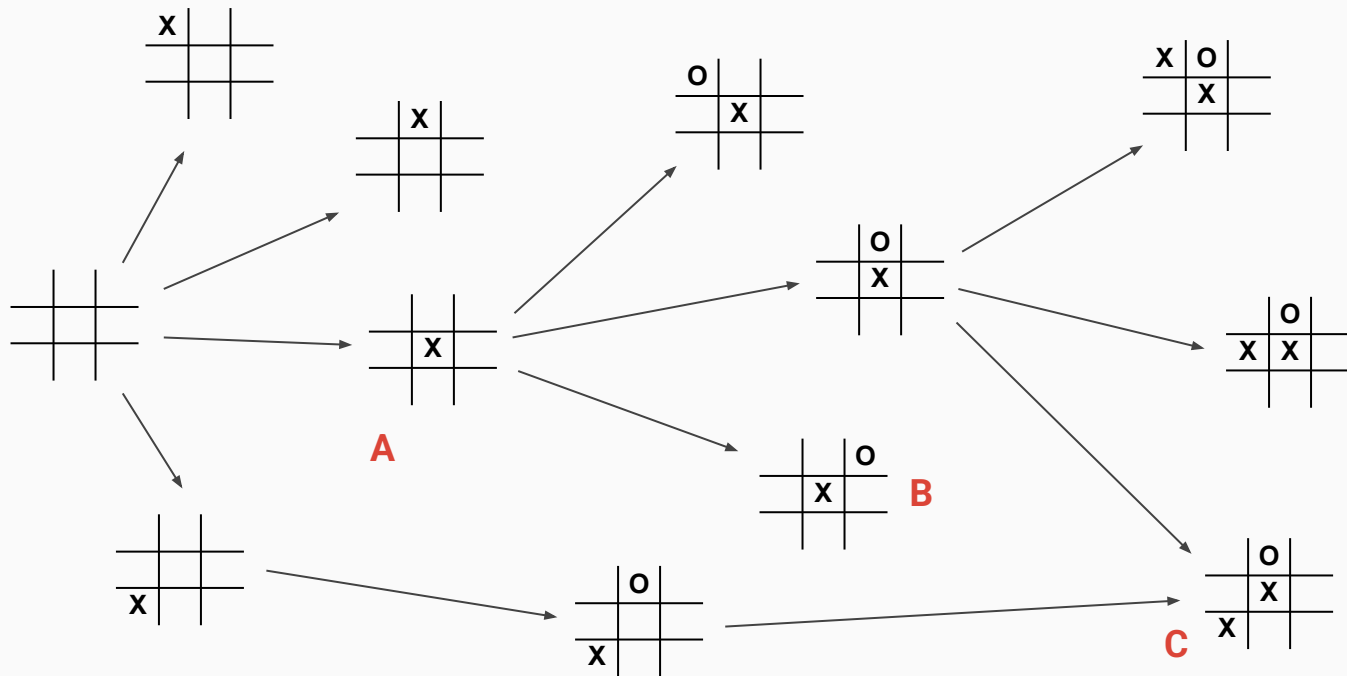

Note: This does not show all edges / vertices...

What is the out degree of the vertex for the empty board? 9
What about the in degree? 0

What is the out degree of the vertex labeled A? B? 8, 7

How many edges are in the full graph? 9!

Is the in degree of every non-starting node 1? No ie C