

Evaluating Logic Gates

To make sense of logic gates, we first need to know what each gate means. Remember there are three basic gates.



The NOT gate:



The AND gate:

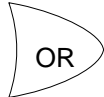

The OR gate:

Example 1:

To understand this circuit, we must know exactly what the symbols mean.

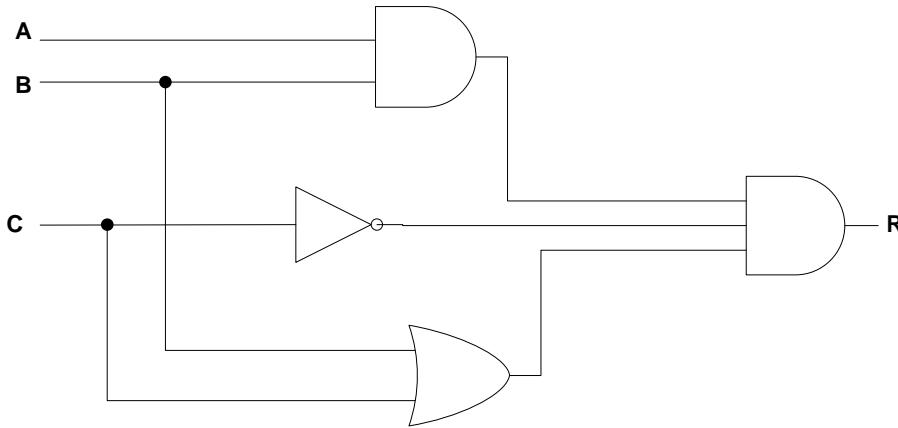

In this version of the circuit, the gates are labeled.

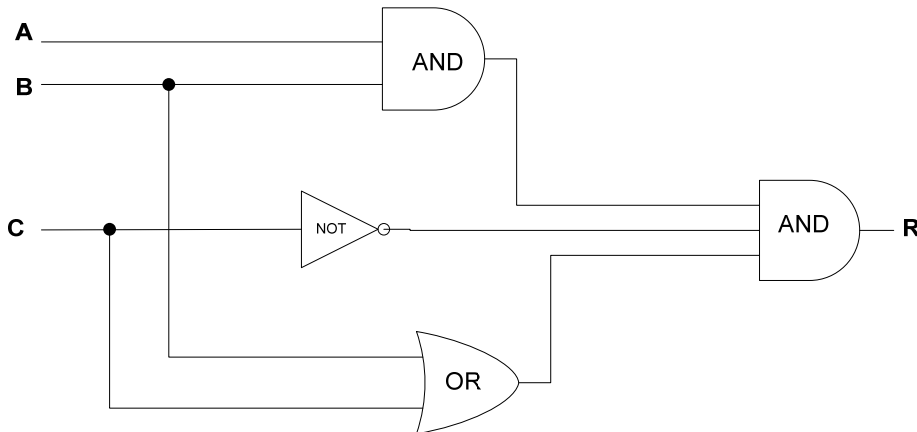

Examining the circuit above, we can ask a number of different types of questions. For example, we can be asked to determine the value of R, given information about A, B, and C. So, If $A = 1$, $B = 0$, and $C = 0$, what is R?

Evaluating Logic Gates

To solve this problem we would trace the circuit writing down the values as we enter and leave each gate. Trace the circuit below and determine the values going into each gate along with the values coming out. As you can see if $A = 1$, $B = 0$, and $C = 0$ then $R = 0$.

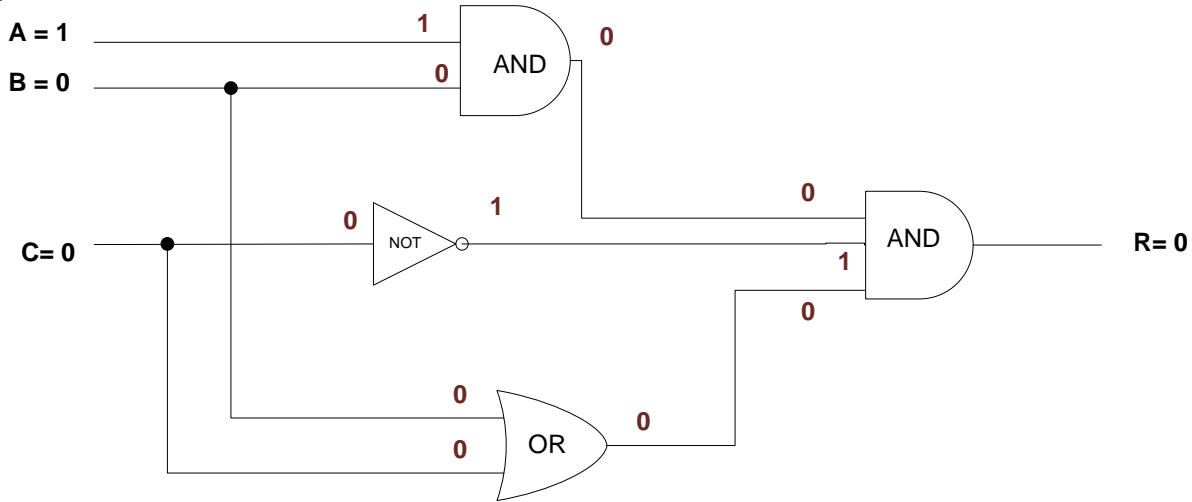

All circuits can also be evaluated using the appropriate logic statement or logic equation and a truth table to determine the various values of R. So, moving between circuits and logic statements is important.

To translate this circuit into the appropriate logic statement we need to use the variables A, B along with C and work through the circuit from left to right and top to bottom carefully matching how the data moves from gate to gate. When determining the logic statement REMEMBER the order of operations matters. Using extra parenthesis can make this process easier.

The order of operations for logic statements is:

1. Parenthesis ()
2. NOT ~
3. AND ●
4. OR +

The circuit above can be translated as follows: The uppermost gate is AND and it takes as input A along with B. (AB) , there is a $\sim C$ involved below it, and the bottom gate is an OR which takes the values of B along with C to become $(B+C)$. The results from all three of these gates becomes the input to the final AND gate.

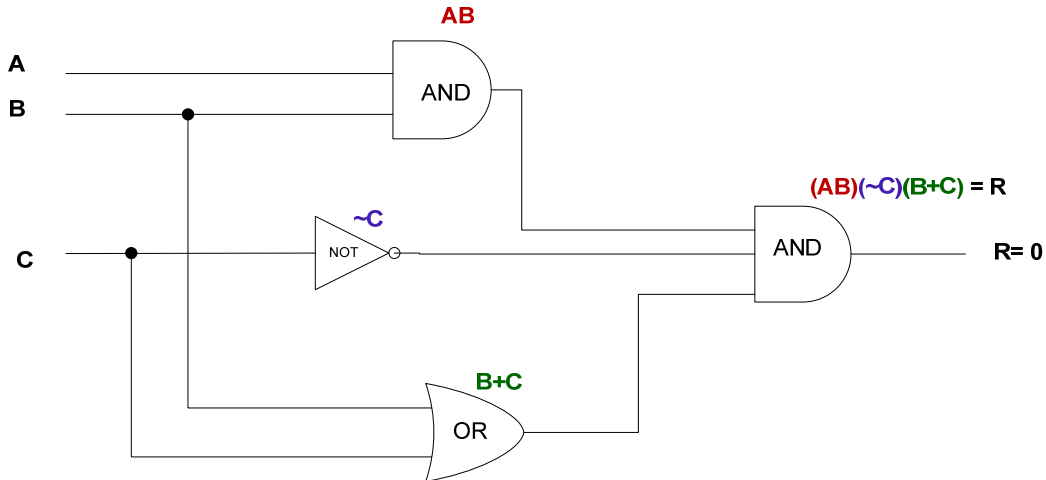

Evaluating Logic Gates

This gives: $(AB)(\sim C)(B+C) = R$

If we chose to we could use a truth table to verify this result.

$$(AB)(\sim C)(B+C) = R$$

A	B	C	AB	$\sim C$	B+C	$(AB)(\sim C)(B+C) = R$
0	0	0	0	1	0	0
0	0	1	0	0	1	0
0	1	0	0	1	1	0
0	1	1	0	0	1	0
1	0	0	0	1	0	0
1	0	1	0	0	1	0
1	1	0	1	1	1	1
1	1	1	1	0	1	0

Example 2:

It does not matter how complex the circuit looks, the process of tracing the circuit and determining the logic sentence is the same. Look at this more complex circuit:

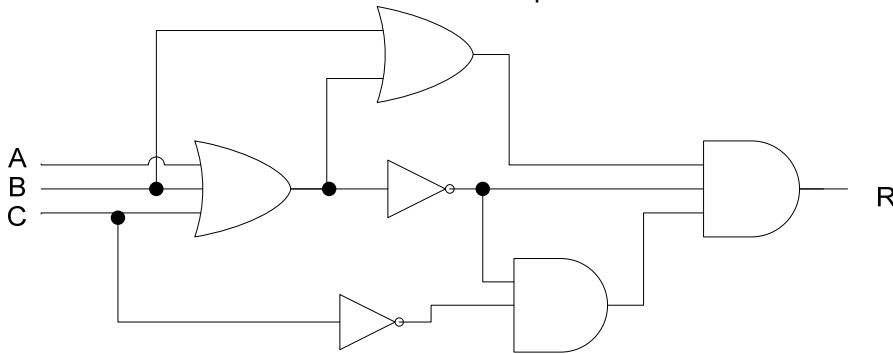

The first step in evaluating any circuit is to be sure we know what each gate means.

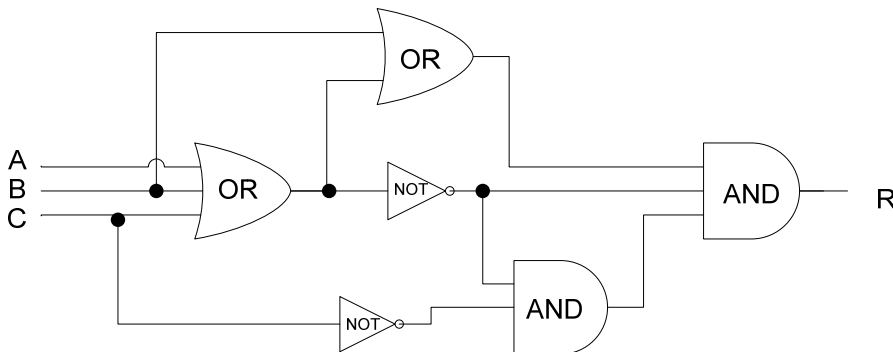

Now we can ask questions about the circuit. Let's let $A = 1$, $B = 0$ and $C = 1$. What is R ? Just as before, write down the values on the circuit just before and just after each gate so we know exactly what the input and output from each gate becomes. In doing so we find that $R = 0$. Use the circuit below to test your work.

Evaluating Logic Gates

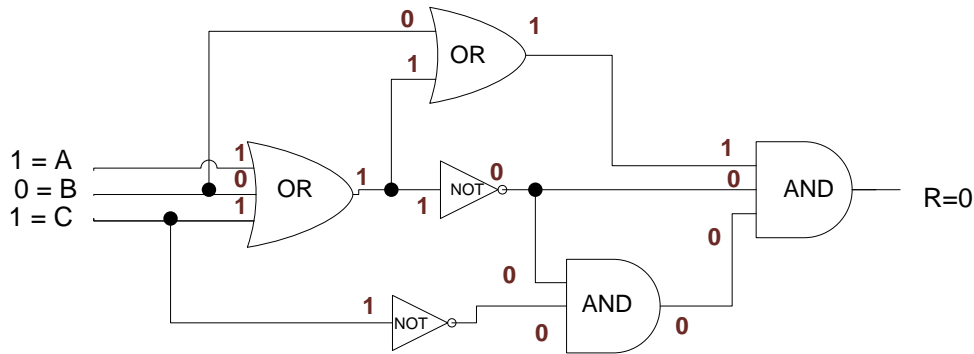

As before, translating this circuit into the logic statement it represents means carefully using the letters A, B along with C to represent the variables going into each gate. The leftmost gate is an OR gate and all three variables are input ($A+B+C$), the uppermost gate is also an OR gate and it takes as input B along with ($A+B+C$), giving $B+(A+B+C)$. In the middle of the circuit, the NOT gate flips the value of ($A+B+C$) giving $\sim(A+B+C)$. The bottom-most AND gate take $\sim C$ as input along with $\sim(A+B+C)$ giving $(\sim C)(\sim(A+B+C))$.

Finally, the right-most AND gate takes as input $(B+(A+B+C))$, along with $\sim(A+B+C)$ and $(\sim C)(\sim(A+B+C))$ to give R.

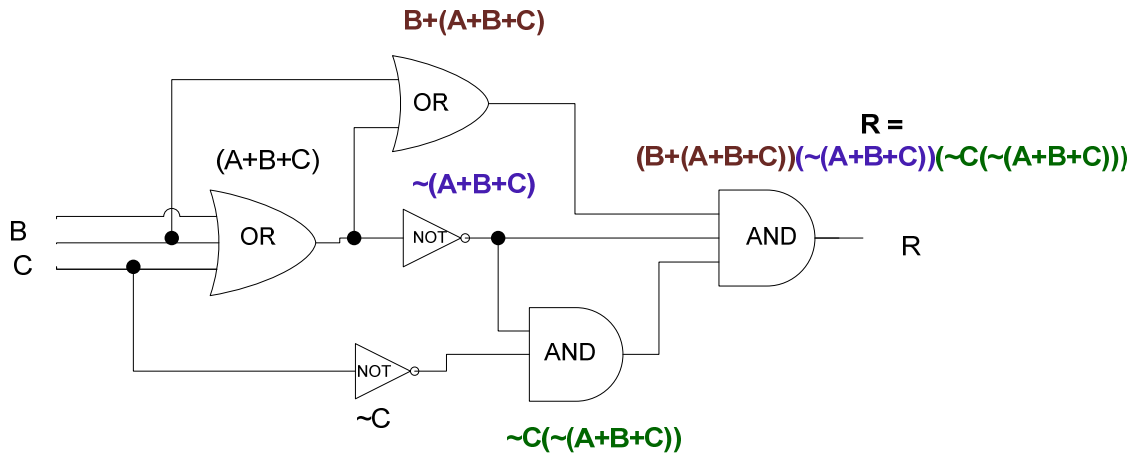

$$R = (B+(A+B+C)) (\sim(A+B+C)) (\sim C(\sim(A+B+C)))$$

A	B	C	A+B+C	$B+(A+B+C)$	$\sim(A+B+C)$	$\sim C$	$(\sim C(\sim(A+B+C)))$	$R=(B+(A+B+C))(\sim(A+B+C))(\sim C(\sim(A+B+C)))$
0	0	0	0	0	1	1	1	0
0	0	1	1	1	0	0	0	0
0	1	0	1	1	0	1	0	0
0	1	1	1	1	0	0	0	0
1	0	0	1	1	0	1	0	0
1	0	1	1	1	0	0	0	0
1	1	0	1	1	0	1	0	0
1	1	1	1	1	0	0	0	0

Evaluating Logic Gates

Example 3: Solve this on your own. The answers are on the next page.

a) If $A = 0$, $B = 0$, $C = 1$, What is R ?

b) Write the Logic statement that represents this circuit.

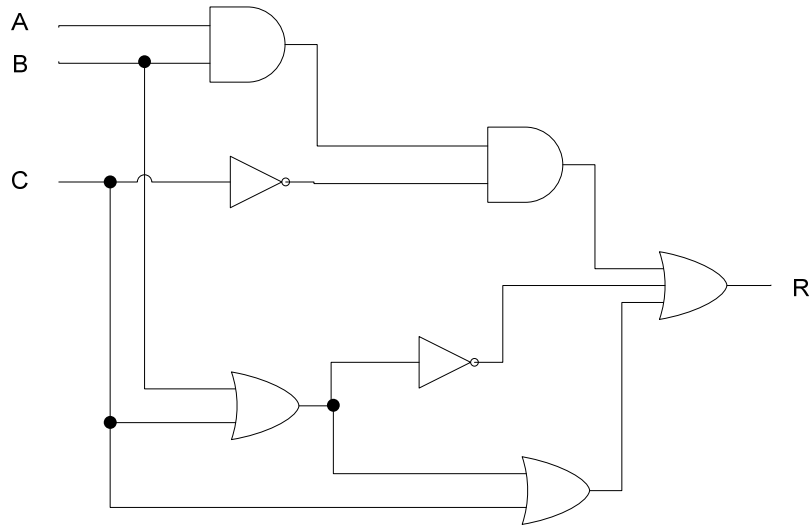

Evaluating Logic Gates

Solution to Example 3a:

Enter the names of the gates.

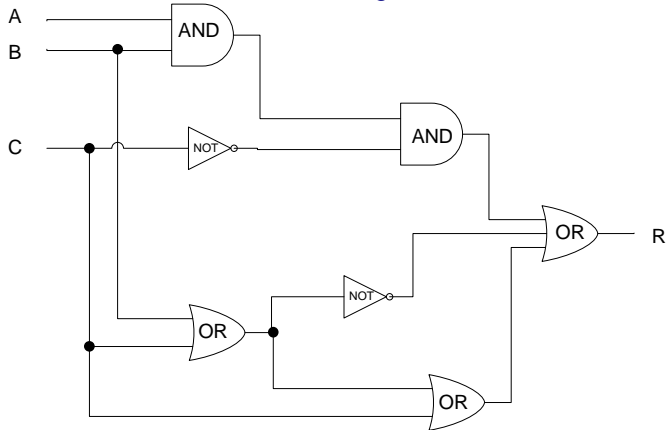

Trace the input and the output through each gate write down the values to determine R.

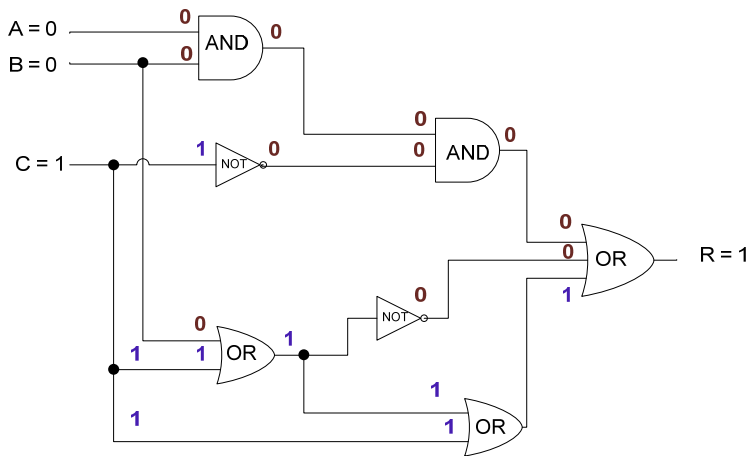

Working gate-by-gate determine the logic statement that matches this circuit.

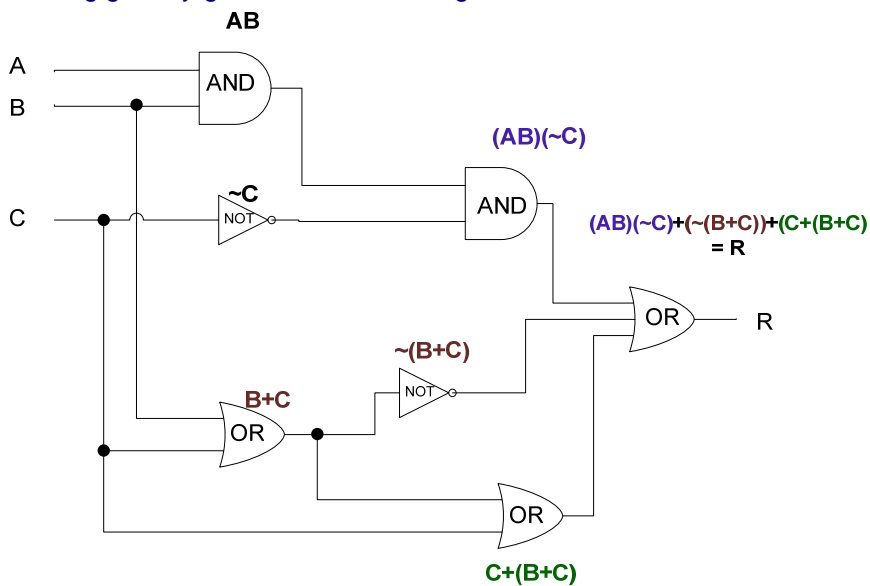

$$R = (AB)\sim C + \sim(B+C) + (C+(B+C))$$