

# A Tour of Computer Systems

CSE 220: Systems Programming

Ethan Blanton

Department of Computer Science and Engineering

University at Buffalo

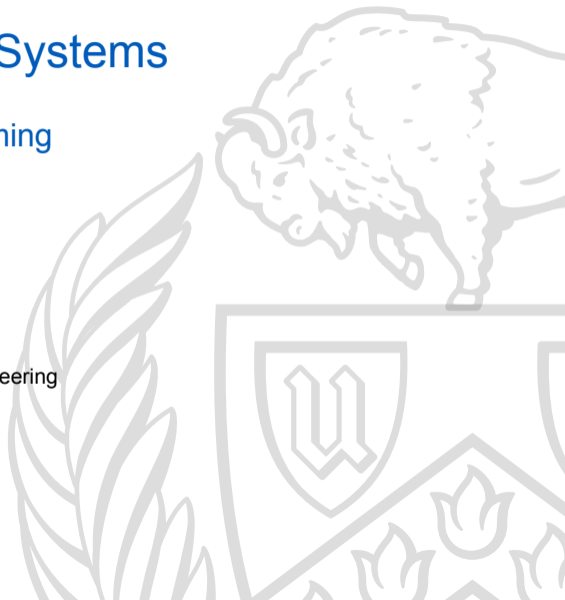

# Concept versus Implementation

The C language and POSIX are **implementations** of systems.

There are many possible implementations.

Certain **conceptual considerations** are presented by underlying architecture.

We will look at some of those concepts.

# Understanding How Things Work

“Why do I need to know this stuff?”

Abstraction is good, but don't forget reality!

Most CS courses emphasize abstraction

- Abstract data types
- Asymptotic analysis

These abstractions have limits

- Sometimes you need to understand the underlying implementation
- Sometimes the abstract interfaces are not as flexible or performant as you need
- Sometimes there are bugs

# Effective Questions

Answering questions is easy.

Asking the right question is hard!

For conceptual problems, ask:

- What do I **have**?
- What do I **need**?
- Can I figure out how to get from here to there?
- What about **partway there**?

If you need help, tell us (in your words!) what you have and what you need!

# Numeric Representations

`ints` are not integers, `floats` are not real numbers!

Example 1: Is  $x^2 \geq 0$ ?

- `float`: yes!
- `int`: well ...
  - $40000 * 40000 \rightarrow 1600000000$
  - $50000 * 50000 \rightarrow ???$

Example 2: Is  $(x + y) + z = x + (y + z)$ ?

- `int`: yes!
- `float`:
  - $(1e20 + -1e20) + 3.14 \rightarrow 3.14$
  - $1e20 + (-1e20 + 3.14) \rightarrow ???$

# Computer Arithmetic

Computer operations **do have** mathematical properties.

However, you **cannot assume** all usual mathematical properties!

- Finite representations cause various effects
- Integer operations satisfy **ring** properties:
  - Commutativity, associativity, distributivity
- Floating point operations satisfy **ordering** properties:
  - Monotonicity, sign values

You must understand **which abstractions apply where**.

These are important issues for compiler writers, systems programmers, **serious application programmers**.

# Assembly Language

You **need to know** assembly.  
You'll see it next in CSE 341!

You'll probably never **write programs** in assembly.  
(Compilers are better at it and much more patient than you are!)

**Understanding assembly** is key to understanding the machine.

# Where Will I Use Assembly?

Understanding the behavior of programs **in the presence of bugs**

- High-level **language models** break down

Tuning program performance

- Understand optimizations the compiler **can and cannot do**
- Understand sources of program inefficiency

Implementing system software

- Compilers target assembly
- Operating systems manage hardware state

Creating and fighting malware

- Most **malware is in x86 assembly!**



# Memory Management and Layout

Memory matters.

Memory is not unbounded!

- It must be allocated and managed
- Many applications are memory-dominated

Memory referencing bugs are especially pernicious

- Their effects may be **distant in both time and space**

Memory performance is not uniform

- Cache and virtual memory effects can affect program performance
- Adapting programs to the memory system can have major speed implications

# Why Memory Performance Matters

```
void copyij(int src[2048][2048],
            int dst[2048][2048]) {
    for (int i = 0; i < 2048; i++) {
        for (int j = 0; j < 2048; j++) {
            dst[i][j] = src[i][j];
        }
    }
}
```

3.8 ms

```
void copyji(int src[2048][2048],
            int dst[2048][2048]) {
    for (int j = 0; j < 2048; j++) {
        for (int i = 0; i < 2048; i++) {
            dst[i][j] = src[i][j];
        }
    }
}
```

72.2 ms

All that changed is **the order of the loops!**

# Therac-25

An infamous accident in software engineering: Therac-25



<https://medium.com/swlh/software-architecture-therac-25-the-killer-radiation-machine-8a05e0705d5b>

- People died.
- Arithmetic bugs were involved.
- Poorly understood copied code was involved.

(Stack Overflow kills!)

# Toyota Acceleration

Some Toyota vehicles experienced unintended acceleration in the late 2000s.

- Toyota was fined **1.2 billion dollars**
- ~9 million vehicles were recalled

Expert analysis identified:

- Memory corruption from software bugs
- Copied code (“Stack overflow ...bugs led to memory corruption”)

From material Copyright Phil Koopman, CC-BY-4.0

[https://users.ece.cmu.edu/~koopman/pubs/koopman14\\_toyota\\_ua\\_slides.pdf](https://users.ece.cmu.edu/~koopman/pubs/koopman14_toyota_ua_slides.pdf)

# Mars Pathfinder

The Pathfinder Mars rover frequently stopped responding.

- The problem was **system scheduling**
- Low-level debugging identified the issue
- Testing **could have identified the problem** on the ground

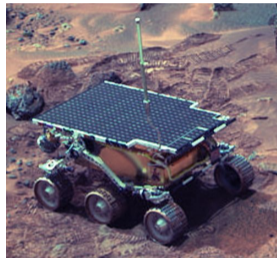

(Credit: NASA)

<https://www.rapitasystems.com/blog/what-really-happened-to-the-software-on-the-mars-pathfinder-spacecraft>

# A Bit About Architecture

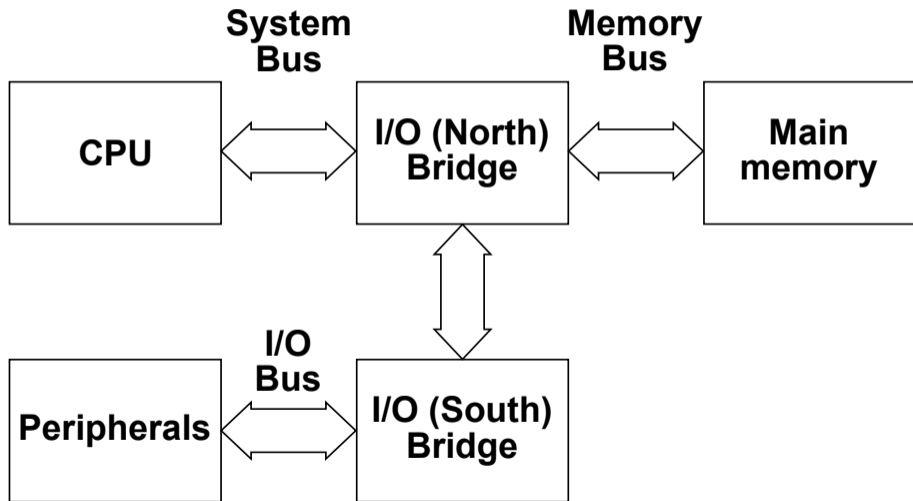

# Buses

A bus has a **width**, which is literally the **number of wires** it has. ¶

(This is a little less clear on a **serial bus**, where the width is a protocol convention.)

Each wire transmits **one bit per transfer**.

*Every bus transfer* is of that width, though some bits may be ignored.

Therefore, memory has a **word size** from the view of the CPU: the number of wires on that bus.

# A Modern CPU

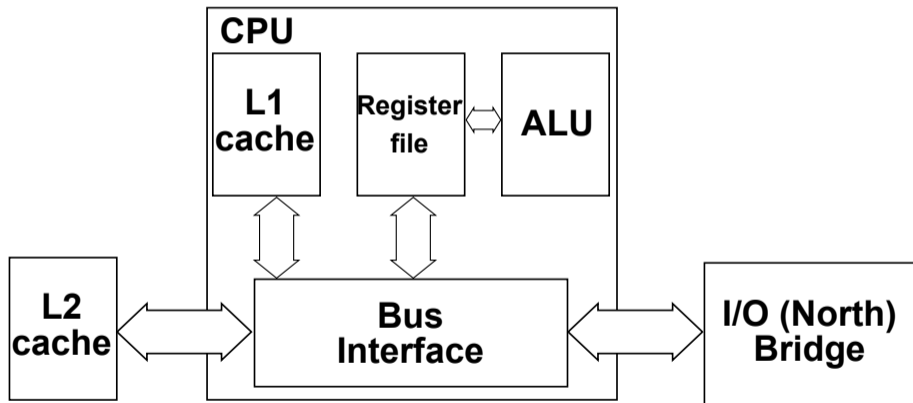



# CPU Properties

Both **internal** and **external** busses have fixed widths.

A small number of storage locations called **registers**:

- Have **very fast** access time ¶
- Have a fixed width
- Are fixed in number

The **ALU** performs computation.

- It may be able to access **only registers**
- It may be able to access **memory**
- It may have **arbitrary restrictions**

# CPU ↔ Memory Transfer

The CPU fetches data from memory in words the width of the memory bus.

It places those words in registers the width of a cpu word.

This register width is the native integer size.<sup>1</sup>

These word widths may or may not be the same.

If they're not, a transfer may require:

- multiple registers, or
- multiple memory transfers.

---

<sup>1</sup>Some CPUs (including x86-64) can manipulate more than one size of integer in a single register.

# Imposing Structure on Memory

That said, programming languages expose things like:

- Booleans
- classes
- strings
- structures

How is that?

We **impose meaning** on words in memory by **convention**.

*E.g.*, as we saw before, a C string is a **sequence of bytes** that happen to be adjacent in memory.

# Summary

- Architectural details matter
  - Bus widths
  - Numeric properties
  - Performance details
- C and POSIX are **just one possible system**
- All systems **have those details**
- Software correctness **can be critically important**

# Next Time ...

- Memory allocation
- The program heap

# References I

## Required Readings

- [1] Randal E. Bryant and David R. O'Hallaron. *Computer Science: A Programmer's Perspective*. Third Edition. Chapter 1: Intro, 1.1–1.7. Pearson, 2016.

# License

Copyright 2020, 2021, 2022 Ethan Blanton, All Rights Reserved.  
Copyright 2019 Karthik Dantu, All Rights Reserved.

These slides use material from the CMU 15-213: Intro to Computer Systems lecture notes provided to instructors using CS:APP3e.

Reproduction of this material without written consent of the author is prohibited.

To retrieve a copy of this material, or related materials, see <https://www.cse.buffalo.edu/~eblanton/>.